

Manual: Measurement of Sound Level

By Igor Grešovnik, June 2002.

1	<i>Physical Foundations of Sound</i>	2
1.1	What is Sound	2
1.1.1	One Dimensional Sound Waves	3
1.1.2	Arbitrary Waves, Spectral Analysis	7
1.1.3	Sound in Three Dimensions	9
1.2	Human Perception of Sound	13
2	<i>Measuring of Noise</i>	14
2.1	Introduction	14
2.2	General Definitions	15
2.2.1	Summary of Important Quantities	15
2.2.2	Frequency Weighting Characteristics	16
2.2.3	Time Weighting Characteristics	20
2.2.4	Band Pass Filters	22
3	<i>The Metrel Sound Level Meter</i>	24
3.1	The Structure of the Instrument	24
3.2	Testing and Measuring Accuracy	26
3.3	Calibration of the Instrument	27
4	<i>Standards</i>	<i>Error! Bookmark not defined.</i>

1 PHYSICAL FOUNDATIONS OF SOUND

1.1 What is Sound

Sound in gas or fluid media is a wave motion of particles¹ of the substance. In a non-disturbed medium being in equilibrium, the pressure and temperature are uniform over the space, different particles of the substance have the same mass density and they do not move with respect to each other. When a certain part of such system is mechanically disturbed by enforcing a local deviation in pressure or by accelerating instantaneously certain particles of the substance, a disturbance is created which propagates through the space by the speed of the sound c , which is characteristic for the given media at a given state. When such disturbance would reach a certain point in the space, parts of the substance at that point would oscillate in the direction of

¹ When describing sound, the particles that we consider are not single molecules of the liquid or gas, but rather small volumetric particles of substance which contain enough molecules that thermodynamic equilibrium can be defined, but are small as compared with the wave length. Movement of particles in sound waves is coherent and has nothing to do with stochastic thermal movement of single molecules.

propagation. Consequently, the density and hence the pressure of the media will also oscillate around their equilibrium values. A variety of combinations of such disturbances, which reach our ears, are able to induce the sensation that we perceive as sound.

Sound waves in gas or fluid media (e.g. in the air) are described by the following space and time dependent quantities: the displacement \mathbf{u} of any particle of the substance from its equilibrium position, pressure $p+\delta p$ and mass density $\rho+\delta\rho$, where δp and $\delta\rho$ are deviations from the equilibrium values p and ρ of the pressure and mass density. δp is commonly called the sound pressure. Displacements in gas or fluid media are always parallel to the travelling direction of waves, i.e. sound is the longitudinal waves¹.

1.1.1 One Dimensional Sound Waves

Some features of the sound can be conveniently explained on the one dimensional model where wave propagation is restricted to a single direction. The sound field which can be well described in one dimension can be generated e.g. in a long narrow tube or by a very large flat membrane whose dimensions are large compared to the wavelength and which oscillates uniformly over its dimensions.

1.1.1.1 Derivation of Sound Properties on Excitation of a Gas Column

Let us observe excitation of gas in a gas column by a piston, which we push by the force F in such a way that it begins to move by the velocity v (Figure 1.1). This forces gas particles at the piston to move at the same velocity v and therefore push and compress the particles in their vicinity. In this way a disturbance is created in which the gas is compressed with respect to initial state. The disturbance propagates in the direction of piston movement by the velocity c greater than v (i.e. its volume s increased) since otherwise the gas near the piston would be compressed infinitely. After the time dt the total mass of the disturbed volume is $\rho S c dt$. Therefore, by the momentum law, $F dt = (\rho S c dt)v$. We define the compressibility of gas as

$$\chi = -dV/(V dp) = S v dt / (S c dt (F/S)) = v S / (cF).$$

By combining the last two equations we obtain an expression for the speed of propagation of the disturbance, which is essentially the *sound speed* for the particular gas:

$$c = \frac{1}{\sqrt{\chi \rho}}. \quad (1.1)$$

The compressed particles are heated a bit, but there is no observable heat exchange between different particles in the disturbance. The adiabatic compressibility χ_s must therefore be used in the above equation. It can be expressed in terms of the isothermal compressibility, which for ideal gases equals to $\chi_T = 1/p$, in the form $\chi_s = \chi_T c_v/c_p = \chi_T/\kappa = 1/(\kappa p)$. κ is the ratio between the specific heat capacity at a constant pressure and the specific heat capacity at a constant volume and

¹ Due to the fact that pure shear strain does not induce any stress in fluid or gas media, transversal waves can not propagate in such media. We can have transversal waves in solids.

1. Physical Foundations of Sound

is always greater than 1 ($\kappa = 1.4$ for the air). The expression for the sound speed can therefore be written as

$$c = \sqrt{\frac{\kappa p}{\rho}}. \quad (1.2)$$

The sound speed in the air at normal conditions is $c = 340 \text{ m/s}$.

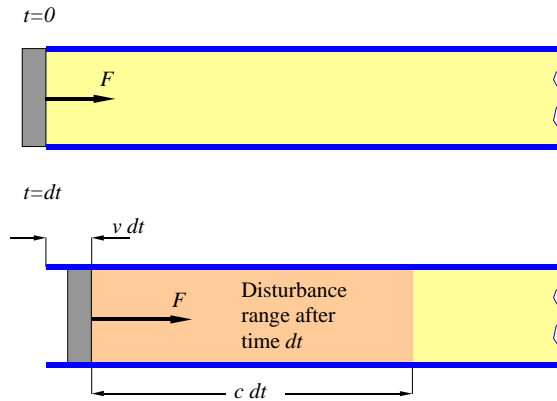

Figure 1.1: travelling of longitudinal disturbance in a column of gas.

After the time dt the particles that are less distant from the piston than $c dt$ move with the velocity v . More distant particles are still since the disturbance has not reached them yet. The piston performs work, which is reflected in the increase of the total energy of the disturbed volume of gas. The work is $dA = F v dt = \rho S c dt v^2$. By dividing this by the volume of the disturbed part we obtain the *density of the additional total energy* in the disturbance:

$$w = \rho v^2. \quad (1.3)$$

A half of this is kinetic energy due to movement of the gas particles while the other half represents the internal energy.

We can express compressibility from equation (1.0: $\chi = -dV/V dp = 1/(\rho c^2)$). On the other hand, $dV/V = du/dx$, where du is the displacement of the piston after the time dt and dx is the length of the disturbed part after this time. We can now express the *pressure deviation* in the disturbance as¹:

$$\delta p = -\rho c^2 (\partial u / \partial x) . \quad (1.4)$$

¹ Partial derivative must be taken since the pressure in the gas column, as well as other quantities, depend both on t and x . The partial derivative with respect to x means differentiation with respect to x while t is kept constant.

The additional internal energy of the disturbance equals the work needed to compress the gas from the initial to the disturbed state. If we did that, the force would linearly increase from 0 to $S \delta p$ on the distance du and the work would be $\frac{1}{2} S \delta p du$. To obtain the *density of the additional internal energy*, we divide this by the volume of the disturbance $S dx$ and obtain

$$w_i = \frac{1}{2} \rho c^2 (\partial u / \partial x)^2 . \quad (1.5)$$

Kinetic energy of an observed particle equals $\frac{1}{2} dm v^2$ where dm is the mass of the particle, therefore the *density of the kinetic energy* in the disturbance is

$$w_k = \frac{1}{2} \rho c^2 (\partial u / \partial t)^2 . \quad (1.6)$$

1.1.1.2 Sinusoidal Waves

Alternatively the piston in the described arrangement can oscillate sinusoidally as $u(x=0) = u_0 \cos(\omega t)$ (Figure 1.2). Particles at the piston are forced to oscillate in the same way as the piston does. This creates a disturbance which propagates away from the piston with the sound speed c and can be observed as a sinusoidal sound wave. Particles at some position x oscillate in the same way as particles near the piston at the earlier time $t - x/c$, when the corresponding part of the wave currently appearing at x was created. The *displacement* at a given time and place is therefore expressed as

$$u = u_0 \cos(\omega t - k x) , \quad (1.7)$$

where

$$k = \omega / c . \quad (1.8)$$

u_0 is the *amplitude* and ω is the *angular velocity* of the oscillation. The argument of the cosine in (1.0), $\omega t - k x$, is referred to as the *phase* of the wave at a given time and space. Alternatively to ω the frequency f can be stated,

$$f = \frac{1}{t_0} = \frac{\omega}{2\pi} , \quad (1.9)$$

where t_0 is the period of the oscillation. Another important quantity is the spatial period of the wave or *wavelength* λ , defined also as the distance between two neighbouring points having maximum displacement u_0 at some given time. From $k \lambda = 2\pi$ following from the definition of λ , (1.0 and (1.0 we have

$$\lambda = c / f . \quad (1.10)$$

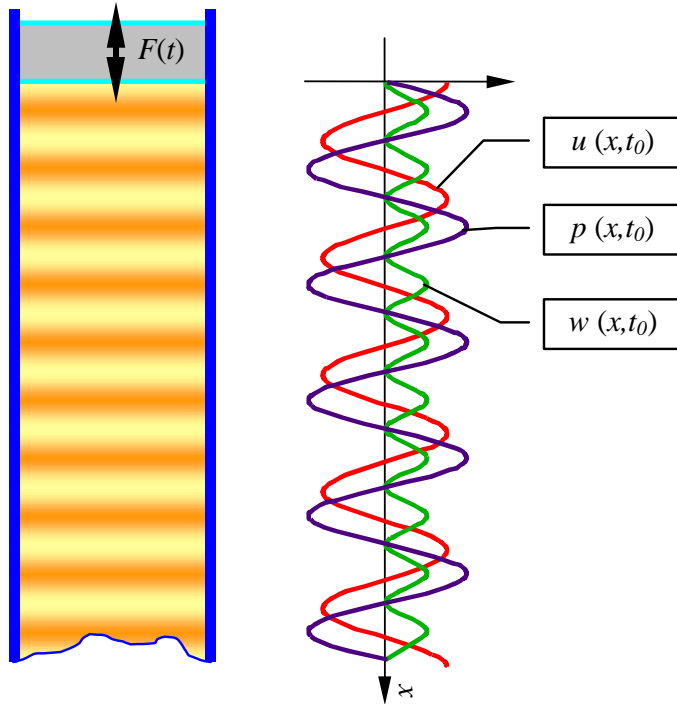

Figure 1.2: Sinusoidal excitation of a gas column. Spatial situation is shown at the time when the piston displacement is zero. Dense and disperse regions in the gas column are shown on the left while the correspondent course of the displacement, pressure and energy density are shown on the right hand side.

Similar conclusions are valid for a sinusoidal wave as those derived above for uniform movement of the piston¹ and equations (1.0 to (1.0 are valid. The *average energy density of the wave* is obtained by averaging (1.0. Since $\overline{\sin^2} = \frac{1}{2}$ over an infinite interval and by taking into account the time derivative of (1.0, which gives the velocity of gas particles, we have

$$\bar{w} = \frac{1}{2} \rho \omega^2 u_0^2. \quad (1.11)$$

The additional energy travels together with the wave. In time t the wave travels the distance ct , therefore in this time the energy flux through a given cross section is

$$P = \bar{W}/t = V \bar{w}/t = S c \bar{w} = S j.$$

¹ We can think of applying the above model in which the piston would start to move uniformly to some time, to a very small particle of gas in which displacements change linearly with the position.

j is the *energy flux density*, also referred to as the *sound intensity*. From the above equation we have $j = c \overline{w}$ and by taking into account (1.0) and then (1.0) we obtain the following equation for the *sound intensity*:

$$j = \frac{1}{2} \rho c \omega^2 u_0^2 = \frac{1}{2} \frac{(\delta p)^2}{\rho c}. \quad (1.12)$$

1.1.2 Arbitrary Waves, Spectral Analysis

Sound waves can have arbitrary form, not just sinusoidal. We can for example combine several sinusoidal waves with different frequencies and amplitudes. The result is a sound wave whose displacement at a given time is a sum of the displacements of individual waves¹.

On the other hand, an arbitrary sound wave can be decomposed into a number of sinusoidal components². This is done by the Fourier transform^[2], which is a linear integral transform. The Fourier transform of the time dependent displacement results in the distribution of the amplitudes of sinusoidal waves, which constitute the wave, in the frequency space. By squaring the absolute of the Fourier transform and multiplying it by the appropriate scaling factor, the *spectrum of the wave* $d j/d \omega$ (or $d j/d f$ when scaled by the factor of) is obtained. It shows the portion of the energy flux density that falls on a small frequency interval around the given frequency.

If the wave is composed of a finite number of sinusoidal waves, it is said to have a *discrete spectrum*. In this case $d j/d f$ is infinite at the frequencies of which the wave is composed and zero elsewhere. In this case we draw j_i in the spectrum rather than $d j/d \nu$, where j_i is the sound intensity of the i -th sinusoidal component that constitutes the wave. The displacement of such a wave is a sum of a number of cosine and sine functions whose frequencies and squares of amplitudes can be read from the spectrum.

The wave is said to have a continuous spectrum when every frequency in a given interval is represented in its spectrum. Rather than by a sum of a finite number of sine and cosine terms, such a wave can be represented as an integral over the angular frequency range of weighted sine and cosine terms, whose argument is the angular frequency (i.e. the parameter of integration) multiplied by the time. This in fact defines the *inverse Fourier transform*. The weighting function in front of the sine and cosine terms is the Fourier transform of the wave.

¹ If frequencies of the combined waves are in rational ratios, such a wave is periodic with the period that is the smallest integer multiple of all individual periods.

² For some waves, the number of sinusoidal components is not finite.

1. Physical Foundations of Sound

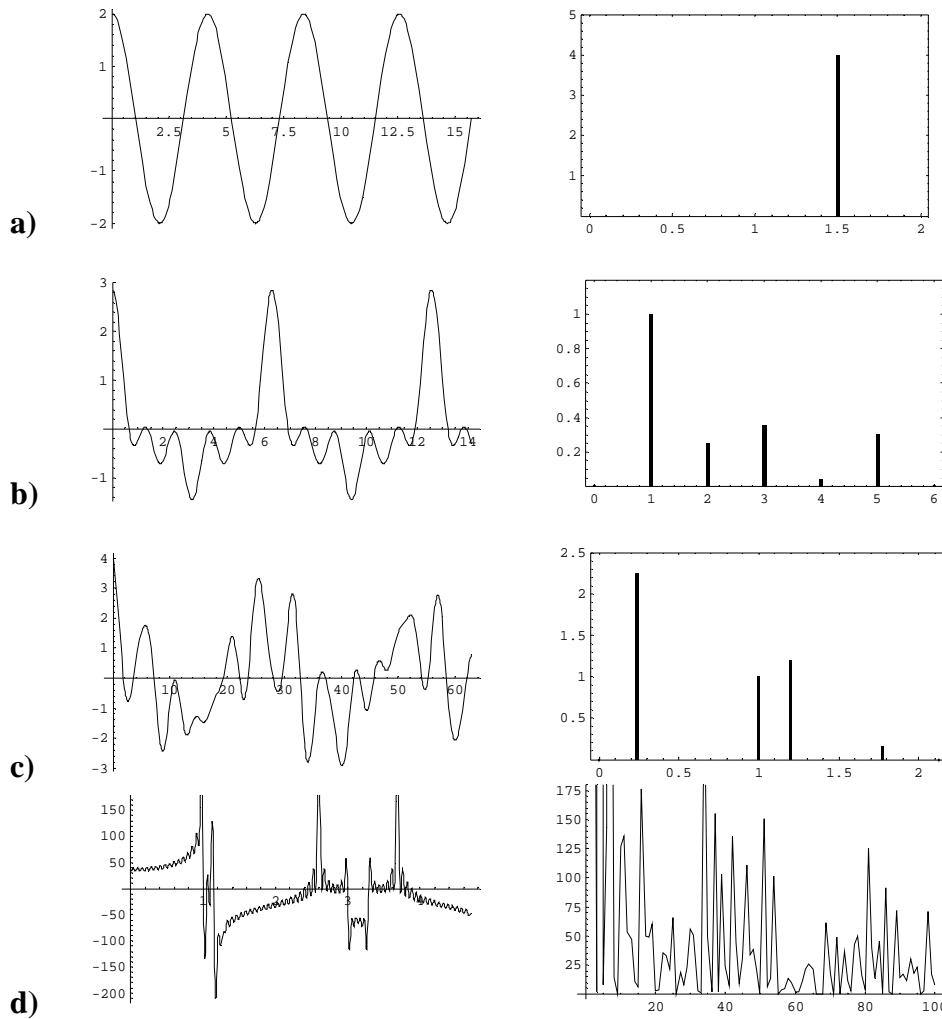

Figure 1.3: Time diagrams $u(t)$ (left) and corresponding spectrums ($j(f)$ or dj/df) for various sounds: **a)** a single frequency tone, **b)** a combination of harmonic sinusoidal waves (frequencies are multiples of the lowest frequency), **c)** a combination of arbitrary sinusoidal waves **d)** noise with continuous spectrum.

Figure 1.3 shows some special cases of sound waves with their spectrums. Just for information, we state here the form of the Fourier transform and its inverse. The Fourier transform of the displacement function $u(t)$ is

$$\hat{u}(\omega) = \int_{-\infty}^{\infty} u(t) e^{-i\omega t} dt, \tag{1.13}$$

while the inverse transform of $\hat{u}(\omega)$ is

$$u(t) = \frac{1}{2\pi} \int_{-\infty}^{\infty} \hat{u}(\omega) e^{i\omega t} d\omega . \quad (1.14)$$

(1.1) The Fourier transform $\hat{u}(\omega)$ of the wave $u(t)$ can be interpreted as a kind of amplitude function of the sinusoidal waves that constitute $u(t)$. This becomes more obvious if we take into account that the integral can be approximated by a sum and that $e^{ix} = \cos(x) + i \sin(x)$. i is the imaginary unit $i = \sqrt{-1}$.

1.1.3 Sound in Three Dimensions

Sound waves can travel in various directions in the space and in general the particular sound field is a combination of waves of different shapes travelling at different directions. Let us first consider a simple case when a sound source emits sinusoidal waves of constant amplitude that are uniformly distributed and have the same phase in all directions. Sound waves travel with the sound speed c radially from the source. If we put the origin of the coordinate system in to the centre of the source, then the displacement of the generated field is expressed as

$$\mathbf{u}(\mathbf{r}, t) = \frac{\mathbf{r}}{r} u_0(r) \cos(\omega t - k r). \quad (1.15)$$

\mathbf{r} is the position vector, r its size and $u_0(r)$ the amplitude of the displacement. Since the source emits the waves evenly in all directions, the size of the displacement at a given time t is the same for all points with the same distance r from the origin. The direction of the displacement is \mathbf{r}/r because sound waves are longitudinal waves in which the displacement is parallel to the direction of propagation.

The sound source performs work with some average power P . By the energy preservation law, the energy flux that exits the sphere at radius r centred around the coordinate origin must be equal to P . Then, by taking into account (1.1), we have

$$P = j(r) S = \frac{1}{2} \rho c \omega^2 (u_0(r))^2 4\pi r^2 .$$

We can write the same equation for some other sphere, e.g. at radius r_0 . Division of both equations yields the *inverse square law* for the sound intensity of the point-like sound source:

$$j(r) = j(r_0) \left(\frac{r_0}{r} \right)^2 . \quad (1.16)$$

Amplitude of the waves falls proportionally to the inverse of the distance from the centre of the source:

$$u_0(r) = u_0(r_0) \frac{r_0}{r}. \quad (1.17)$$

The sound field around the source is then

$$\mathbf{u}(\mathbf{r}, t) = \frac{\mathbf{r}}{r} u_0(r_0) \frac{r_0}{r} \cos(\omega t - k r). \quad (1.18)$$

The inverse square law can be applied even if the sound source does not emit the sound uniformly in all directions. However, the distance from the source must be large compared to the size of the source. Close to a large flat source the wave fronts are more parallel and the surface area through which a certain package of waves travels does not increase by the square of the distance.

Because the sound are waves, we can observe the following phenomena which are characteristic for waves in general ():

Reflection and transmission with diffraction: When travelling sound waves hit an obstacle composed of a different substance, a portion of the waves is reflected back into the first medium. The angles of incidence of the coming and reflected waves are the same. The rest of the waves are transmitted into the second substance. The angle of incidence of the transmitted waves changes in accordance with the ratio of the sound speeds in both media (this is called diffraction).

Bending: When sound waves hit an obstacle of a finite size, the waves are bent into the geometric shadow of the obstacle. When for example plain waves hit a hole in a wall obstacles, the part of the waves which gets through the hole continues to propagate also in the directions different from the direction of incidence of the original waves. This phenomenon takes place any time the amplitude of the waves is considerably changed at the distance of the wave length. Obstacles much smaller than the wave length do not disturb the waves.

Superposition and interference: Sound waves coming from different sources are superposed. The displacement, pressure or density of the particles in the overall sound field oscillates as the sum of these quantities obtained when only individual sources are present. The consequence of this is interference, which appears when two or more sources of the single tone sound of the same frequency are placed side by side, distant for a few wavelengths. In certain directions far away from the sources we can observe waves of higher intensity, while in the directions between them the wave intensity is weakened. The directions of the higher intensity are formed by points at which phase differences of the waves coming from different sources are close multiples of 2π , since in these points amplitude of the superposed oscillations are added together.

Standing waves: The standing wave is obtained by superposition of two waves coming from the opposite directions, but having the same frequency and amplitude. In the sound field produced in this way, there are regions in which the sound intensity is high, while in the others it is low and falls to zero in the so called knots. The distance between neighbouring knots is a half of the wavelength. All particles between two neighbouring knots oscillate in phase, but with amplitude that varies as the sine function. In each knot the oscillating quantities change the sign. The phenomena of standing waves is exploited in music instruments for generation of sounds (tones in the musical terminology) that consist only of the basic and the higher harmonic sinusoidal components, e.g. by pipes or strings.

1. Physical Foundations of Sound

Throbbing: If two sinusoidal waves with slightly different frequencies are superimposed at a given point, the intensity of the superposed wave oscillates by the frequency that equals the difference of both frequencies. This phenomenon can be exploited for tuning of a single frequency source with a reference source.

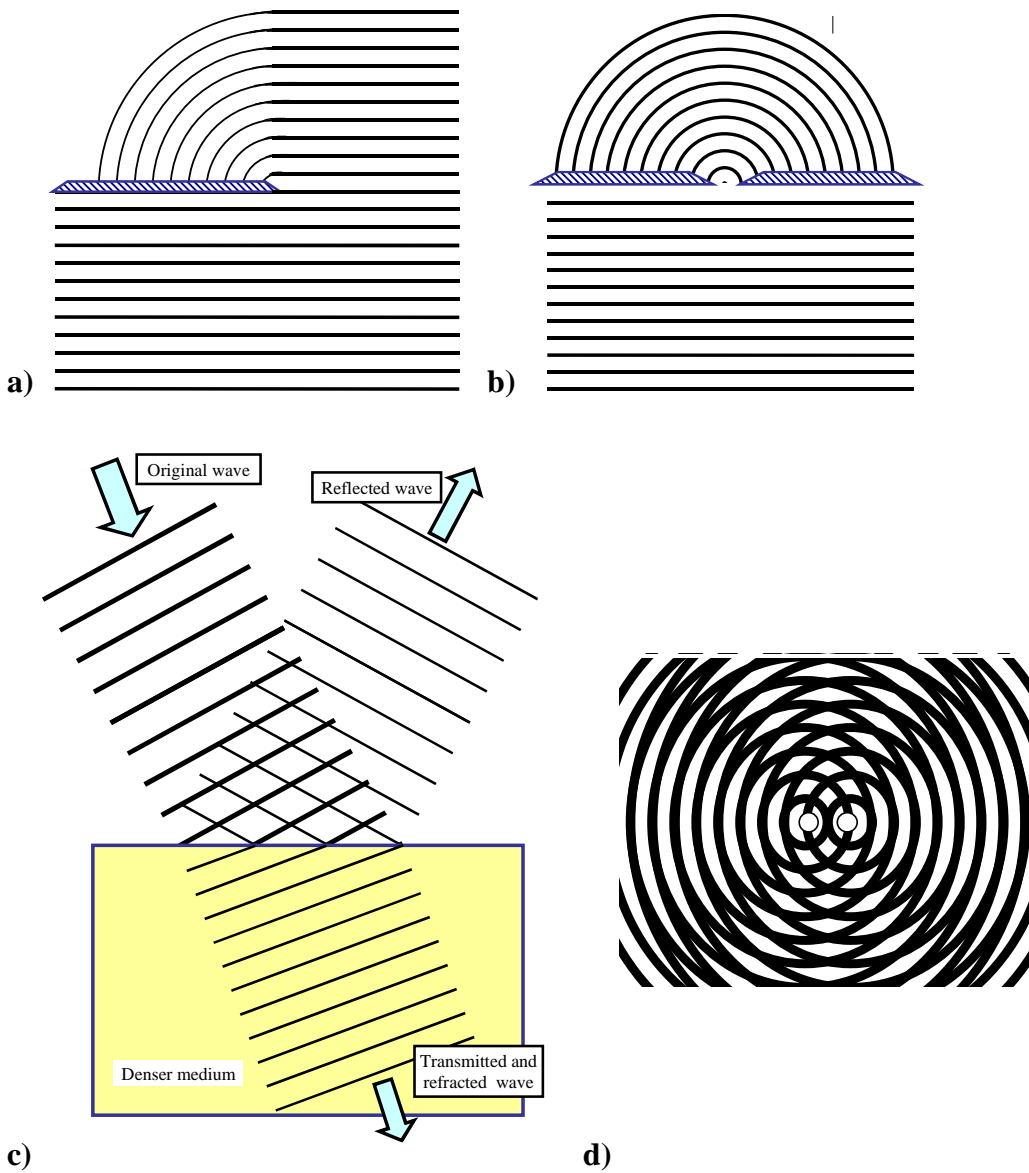

Figure 1.4: schematic demonstration of some properties of the sound waves: **a)** bending into geometric shadow of an obstacle, **b)** bending after passage through a narrow hole, **c)** reflection and transmission on a border between scarce and dense substance, and **d)** interference of waves with equal wavelength emitted by two distinct sources.

The above mentioned phenomena have important practical implications for measurement of noise. Because of bending, reflection and transmission, it is not easy to eliminate from the space the sounds which we do not want to measure. Measurements of sound emission of devices are therefore performed in special chambers that are carefully sound isolated. In such a chamber we must eliminate obstacles that could reflect the sound and in this way affect the results. Because of the interference, the sound intensity can vary a lot over space. In order to perform meaningful measurements of sound emission, it is sometimes not enough to measure the intensity in a particular point, but one might want to integrate the intensity over the particular area of interest. Similarly, integration of longer time intervals might be required.

1.1.3.1 Mathematical Formalism

This section introduces a more rigorous derivation of the equations that govern the sound waves in gas¹. It is informative and is not vital for understanding of other parts of this manual.

As it was mentioned before, the sound is constituted of oscillation of gas particles. Small volumes of gas move with respect to each other and change the volume (and therefore the pressure and density) in the course of this movement. We will make a few assumptions, which in general hold very precisely for the sound fields of practical interest. We will neglect the heat conduction between gas particles and the viscosity of the gas. This is admissible since the absorption of sound in gases is hardly detectable in the range of hearing frequencies. We also assume that displacements are normally small with respect to the wavelengths².

The first equation we use is the basic equation of motion and is the third Newton's law in the differential form:

$$\rho \frac{\partial^2 \mathbf{u}}{\partial t^2} = -\nabla \delta p. \quad (1.19)$$

The preservation of mass requires that the change of mass in a given volume equals the mass that is brought into this volume from its environment. Stated in a differential form, this gives the equation

$$\rho \nabla \cdot \mathbf{u} = -\delta \rho. \quad (1.20)$$

We now have two equations for three unknowns, therefore one more is needed. Beside the basic physical laws we also take into account the behaviour of the particular gas, which can be described by the following state equation:

$$\frac{\delta \rho}{\rho} = \chi_s \delta p \quad (1.21)$$

¹ There are some physical inconsistencies in the derivation of the section 1.1.1.1, e.g. the piston can not accelerate instantaneously from zero to some finite velocity. Besides, the equations derived in this section are general and govern the behaviour of any sound field in the space.

² The above assumptions can not be adopted under extreme conditions, e.g. when the pressure field in explosions is treated.

We can now eliminate \mathbf{u} and $\delta\rho$ from the three equations above. In this way the following *wave equation* for δp is obtained:

$$\nabla^2 \delta p = \frac{1}{c^2} \frac{\partial^2 \delta p}{\partial t^2}, \quad c = \frac{1}{\sqrt{\chi_s \rho}}. \quad (1.22)$$

Any sound field in gas satisfies the equation (1.0) and is in addition determined by the boundary and initial conditions. It can be verified that for example that the sound fields (1.0) and (1.0) satisfies (1.0). From this it can be concluded that c in the equation is the sound speed. (1.0) is a linear homogeneous partial differential equation. A linear combination of two solutions is therefore another solution of the equation. The consequence is the principle of superposition, which implies that multiple sound waves are combined in such a way that displacements or pressures of individual waves are added together.

1.2 Human Perception of Sound

The frequency range of the sound which humans can hear (audible sound) is around 16 Hz to 20 kHz. For the air at normal conditions, where the sound speed is 340 m/s, this corresponds to wavelengths between approximately 21 m and 17 mm. The sensitivity of hearing varies significantly with frequency and is the best in the range of 2 and 3 kHz.

The smallest sound intensity which humans can perceive at the frequency of 1 kHz is

$$j_0 = 10^{-12} \text{ W/m}^2. \quad (1.23)$$

This corresponds to the displacement amplitude of approximately $u_0 = 1.1 \cdot 10^{-11} \text{ m}$ and to the sound pressure amplitude of $(\delta p)_0 = 2.8 \cdot 10^5 \text{ N/m}^2$ (equation 1.1). The sound intensity which causes pain is about 1 W/m^2 , which at the frequency of 1 kHz corresponds to $u_0 = 1.1 \cdot 10^{-11} \text{ m}$ and $(\delta p)_0 = 2.8 \cdot 10^5 \text{ N/m}^2$.

The sensation of the sound is proportional to the logarithm of the sound intensity¹, which enables good navigation through a bunch of signals with significantly different intensities. It is therefore sensible to introduce a logarithmic measure of loudness. We introduce the unit of decibel (dB) and define the *sound pressure level* L_p measured in dB as

$$L_p [\text{dB}] = 10 \log_{10} \frac{j}{j_0} = 20 \log_{10} \frac{p}{p_0}. \quad (1.24)$$

¹ This is known as the Weber-Hefner law and applies also to other senses.

j_0 is the reference sound intensity of 10^{-12} W/m², which is (statistically) the smallest intensity at 1 kHz which human with normally developed sense of hearing can perceive. p_0 is the correspondent reference sound pressure of $20\mu Pa$.

Humans can distinguish frequencies of the sound waves very well. This is the foundation of experiencing the music. We can even feel the difference in sound fields of the same basic (i.e. the lowest) frequency and loudness, but which have different composition with respect to higher harmonic components. We sense this as different quality of tones. Composition with respect to higher harmonic waves is (beside the time dependency of intensity) the basic characteristics by which different music instruments are distinguished, and also the basic characteristics of different vowels in human speech.

The greatest motivation for measuring the sound in various environments is the fact that noise of different kinds appears disturbing and can even damage the sense of hearing if the intensity or time of exposure is high. Noise can disturb concentration, obstruct audible communication and prevent perception of other important sound signals in working environment. Various quantities were defined in an attempt to quantify undesirable effects of noise on people. These try to take into account the frequency response of human hearing organs, the fact that bad effects of the noise depends on the intensity as well as the duration, the fact that sounds concentrated in narrow frequency intervals are more disturbing than sounds with more uniform spectrum, and the fact that short high level sounds are more harmful than long low level sounds whose total energy is the same.

Characteristics of human sense of hearing are captured in a number of standards^{[3]-[7]} which define requirements for the equipment aimed for noise measurements and define the way in which noise level measurements should be performed and how the results should be quantified¹.

2 MEASURING OF NOISE

2.1 Introduction

The task of noise measurement is to quantify the amount of noise in a reproducible manner and in such a way that the quantities measured reflect the effect of the measured noise on humans as much as possible. A number of international standards ([3] - [7]) define the quantities which the measuring equipment must be able to measure, the required response of the measuring equipment to various prescribed sound fields with corresponding tolerances, and tests for testing the compliance of the equipment with the standards. These standards are published by the International Electrotechnical Commission (IEC).

The IEC standards define four types of instrument with respect to the prescribed tolerances: type 0 (the most accurate), type 1, type 2 and type 3 instrument. Standards [3] and [4] define general requirements for sound level meters related to time and frequency weighting characteristics. Standard [6] defines the requirements for integrating sound level meters. While the conventional

¹ One must be aware that the sensation of sound is subjective and varies from individual to individual. The rules for quantification of noise can therefore be defined on basis of statistical investigations, but will not exactly match the response of a particular person.

sound level meters have a limited number of fixed and relatively short duration averaging characteristics¹, averaging periods for the integrating sound level meters are much longer and can extend to many minutes or even hours. The standard [7] defines the requirements for octave-band and third-octave band filters, which are conventionally used for rough spectral analysis of the measured noise.

2.2 General Definitions

2.2.1 Summary of Important Quantities

Beside the sound pressure level L_p , several other quantities are defined in order to quantify the effect of noise on humans. The *weighted sound pressure levels* L_A , L_B and L_C are the pressure levels obtained by applying frequency weighting filters before calculating the pressure level. For example, the L_A is calculated according to the formula

$$L_A(t) = 20 \log_{10} \frac{p_A(t)}{p_0}, \quad (2.25)$$

where p_0 is the reference pressure of $20 \mu Pa$ and p_A is the pressure obtained after application of the A – frequency weighting to the sound pressure p .

Since in general the level of noise changes over time, several integral quantities are defined to quantify the noise level in a comparable and stable manner. The *equivalent continuous sound pressure level* L_{eq} in decibels is defined as

$$L_{eq} = 10 \log_{10} \left(\frac{1}{t_0} \int_{t_1}^{t_2} 10^{0.1L(t)} dt \right), \quad (2.26)$$

where $t_0 = t_2 - t_1$ is the time of measurement. It represents an the average of the total sound energy over the time interval t_0 , expressed as a level in decibels.

The *single-shot sound exposure level* L_{AE} in decibels is defined as

$$L_{AE} = 10 \log \left(\frac{1}{T_0} \int_{t_1}^{t_2} 10^{0.1L(t)} dt \right), \quad T_0 = 1s. \quad (2.27)$$

¹ In order to indicate the measured sound level in such a way that it can be followed, averaging must be inevitably introduced, since in general the fluctuations in sound pressure level may be too quick for humans to follow.

This quantity is aimed at measuring noise of short duration generated only once or intermittently. It equals the sound level of a continuous steady sound whose energy released in one second equals the total energy released in the measured short duration noise.

The *percentile sound pressure level* L_x is a statistical quantity. If the period in which the noise level exceeds a certain level equals $x\%$ of the measuring period, then that sound level is called X percentile sound pressure level or L_x .

2.2.2 Frequency Weighting Characteristics

The IEC standards defines the three frequency weighting characteristics for sound level meters: A, B, C. Additionally the unweighted (Lin or Flat) characteristics may be provided in which the response is independent of the frequency. The weighted output amplitude of a sinusoidal wave at a particular frequency is equal to the input amplitude multiplied by the corresponding frequency response R . Frequency weighting is applied to the amplified output signal of the microphone.

A-weighting (Figure 2.1) simulates the frequency response of the human hearing, where sensitivity decreases significantly at lower and higher audible frequencies. The relative frequency response for A-weighting is

$$R_A(f) = \frac{(12200\text{Hz})^2 f^4}{(f^2 + (20.6\text{Hz})^2)(f^2 + (12200\text{Hz})^2)\sqrt{f^2 + (107.7\text{Hz})^2}\sqrt{f^2 + (737.9\text{Hz})^2}} \quad (2.28)$$

The relative frequency response for B-weighting (Figure 2.2) is

$$R_B(f) = \frac{(12200\text{Hz})^2 f^3}{(f^2 + (20.6\text{Hz})^2)(f^2 + (12200\text{Hz})^2)\sqrt{f^2 + (158.5\text{Hz})^2}} \quad (2.29)$$

The C-weighting gives a relatively flat frequency response (Figure 1.1) and is used for AC outputs of the sound level meter or for measurements of impulsive sounds.

$$R_C(f) = \frac{(12200\text{Hz})^2 f^2}{(f^2 + (20.6\text{Hz})^2)(f^2 + (12200\text{Hz})^2)} \quad (2.30)$$

The corresponding expressions for the A-, B- and C- weighting relative frequency response levels, relative to the response at 1 kHz, are given by

$$\begin{aligned} A(f) &= 20 \log_{10}(R_A(f)/R_A(1\text{kHz})) \\ B(f) &= 20 \log_{10}(R_B(f)/R_B(1\text{kHz})) \\ C(f) &= 20 \log_{10}(R_C(f)/R_C(1\text{kHz})) \end{aligned} \quad (2.31)$$

2. Measuring of Noise

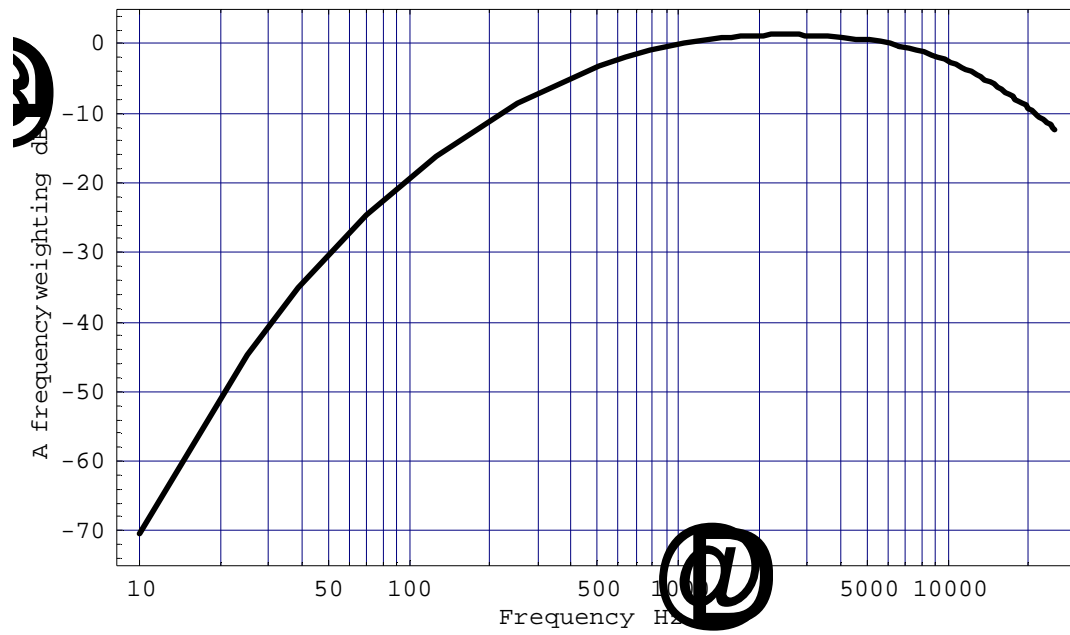

Figure 2.1: The A weighted frequency response.

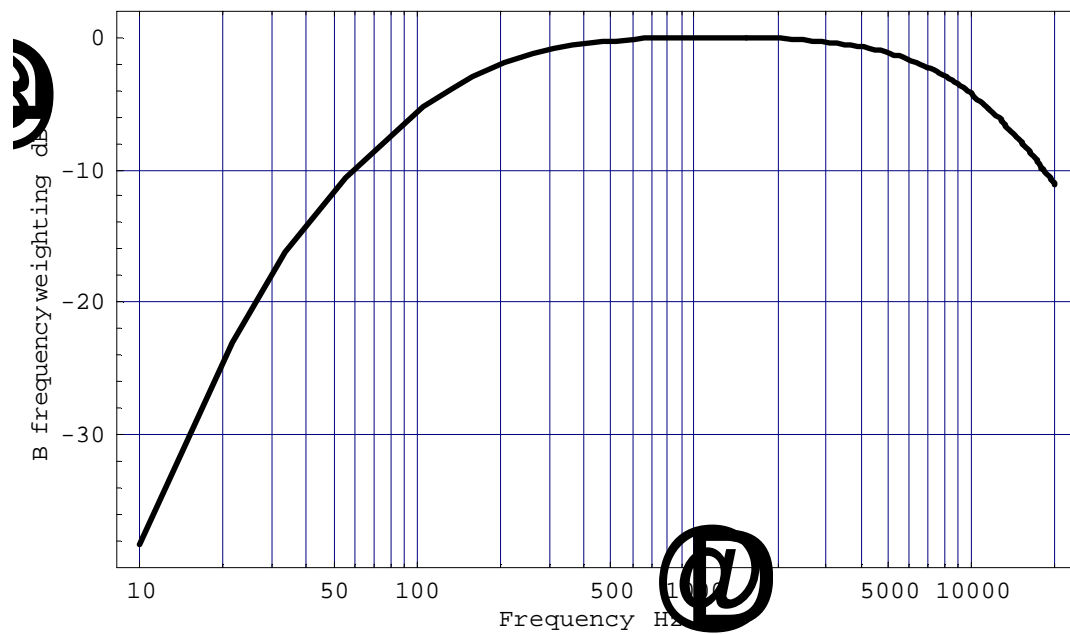

Figure 2.2 The B weighted frequency response.

2. Measuring of Noise

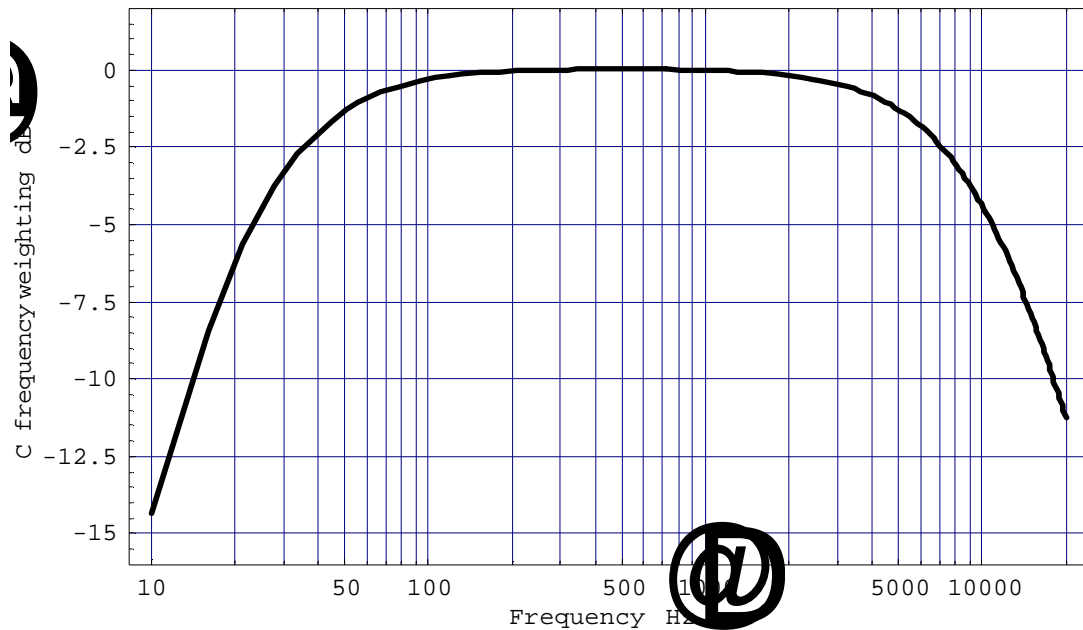

Figure 2.3 The C weighted frequency response.

Figure 2.4 shows the comparison of the A-, B- and C- frequency response. These responses can be realised by cascades of analogue first order low- and high-pass filters, as it is shown in Figure 2.5.

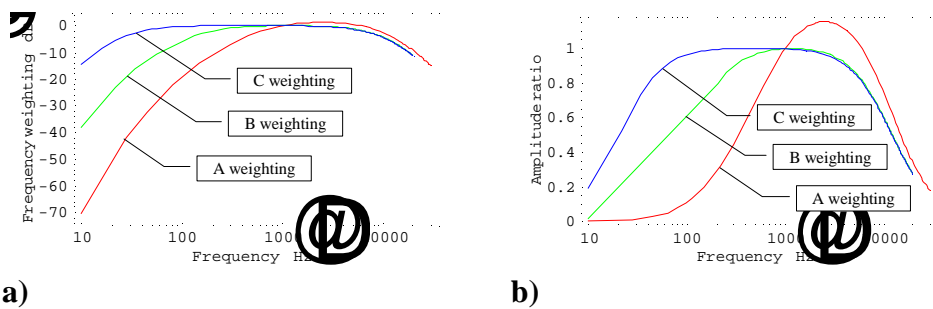

Figure 2.4 Comparison of A, B and C weighting characteristics with frequency plotted in **a)** logarithmic and **b)** linear scale.

2. Measuring of Noise

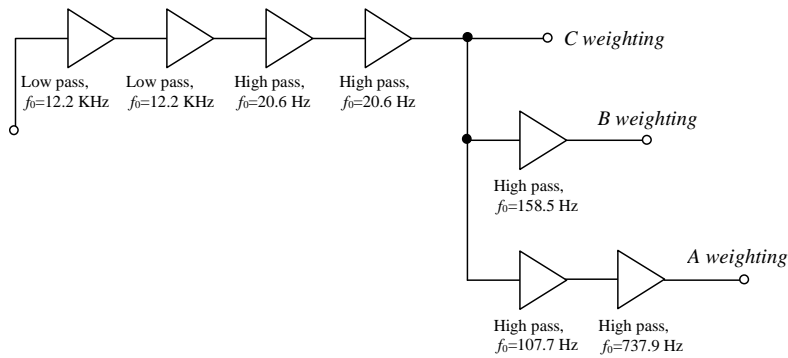

Figure 2.5 Realisation of A-, B- and C- frequency weighting circuits by chains of low- and high- pass first order circuits.

The required frequency response for weightings A, B and C, as specified by the IEC standard [3], is tabulated in Table 2.1. The corresponding tolerances for instruments of type 0, 1 and 2 are listed in Table 2.2. The type 0 instruments are normally used for calibration purposes, while for measurement standards usually the use of type 1 or type 2 instruments is recommended.

Table 2.1: A, B and C weighted frequency response in decibels as specified by the standard [3]. n is a frequency measure, namely the actual (exact) frequency is obtained for a given n as $f(n) = 1\text{KHz} \cdot 10^{0.1n}$. Nominal frequencies are specified in the table, which are rounded actual frequencies.

n	nom. f	A wt.	B wt.	C weighting
-20	10	-70.4	-38.2	-14.3
-19	12.5	-63.4	-33.2	-11.2
-18	16	-56.7	-28.5	-8.5
-17	20	-50.5	-24.2	-6.2
-16	25	-44.7	-20.4	-4.4
-15	31.5	-39.4	-17.1	-3.0
-14	40	-34.6	-14.2	-2.0
-13	50	-30.2	-11.6	-1.3
-12	63	-26.2	-9.3	-0.8
-11	80	-22.5	-7.4	-0.5
-10	100	-19.1	-5.6	-0.3
-9	125	-16.1	-4.2	-0.2
-8	160	-13.4	-3.0	-0.1
-7	200	-10.9	-2.0	-0.0
-6	250	-8.6	-1.3	-0.0
-5	315	-6.6	-0.8	-0.0
-4	400	-4.8	-0.5	-0.0
-3	500	-3.2	-0.3	-0.0
-2	630	-1.9	-0.1	-0.0
-1	800	-0.8	0	-0.0
0	1000	0	0	0
1	1250	0.6	0	-0.0
2	1600	1.0	0	-0.1
3	2000	1.2	-0.1	-0.2
4	2500	1.3	-0.2	-0.3
5	3150	1.2	-0.4	-0.5
6	4000	1.0	-0.7	-0.8
7	5000	0.5	-1.2	-1.3

2. Measuring of Noise

8	6300	-0.1	-1.9	-2.0
9	8000	-1.1	-2.9	-3.0
10	10000	-2.5	-4.3	-4.4
11	12500	-4.2	-6.1	-6.2
12	16000	-6.6	-8.4	-8.5
13	20000	-9.3	-11.1	-11.2

Table 2.2: Admitted tolerances for weighted frequency response for sound level meters of type 0, 1 and 2, in decibels, as specified by [3].

n	nom. f	0-	0+	1-	1+	2-	2+
-20	10	-1e30	2	-1e30	3	-1e30	5
-19	12.5	-1e30	2	-1e30	3	-1e30	5
-18	16	-1e30	2	-1e30	3	-1e30	5
-17	20	-2	2	-3	3	-3	3
-16	25	-1.5	1.5	-2	2	-3	3
-15	31.5	-1	1	-1.5	1.5	-3	3
-14	40	-1	1	-1.5	1.5	-2	2
-13	50	-1	1	-1.5	1.5	-2	2
-12	63	-1	1	-1.5	1.5	-2	2
-11	80	-1	1	-1.5	1.5	-2	2
-10	100	-0.7	0.7	-1	1	-1.5	1.5
-9	125	-0.7	0.7	-1	1	-1.5	1.5
-8	160	-0.7	0.7	-1	1	-1.5	1.5
-7	200	-0.7	0.7	-1	1	-1.5	1.5
-6	200	-0.7	0.7	-1	1	-1.5	1.5
-5	315	-0.7	0.7	-1	1	-1.5	1.5
-4	400	-0.7	0.7	-1	1	-1.5	1.5
-3	500	-0.7	0.7	-1	1	-1.5	1.5
-2	630	-0.7	0.7	-1	1	-1.5	1.5
-1	800	-0.7	0.7	-1	1	-1.5	1.5
0	1000	-0.7	0.7	-1	1	-1.5	1.5
1	1250	-0.7	0.7	-1	1	-1.5	1.5
2	1600	-0.7	0.7	-1	1	-2	2
3	2000	-0.7	0.7	-1	1	-2	2
4	2500	-0.7	0.7	-1	1	-2.5	2.5
5	3150	-0.7	0.7	-1	1	-2.5	2.5
6	4000	-0.7	0.7	-1	1	-3	3
7	5000	-1	1	-1.5	1.5	-3.5	3.5
8	6300	-1.5	1	-2	1.5	-4.5	4.5
9	8000	-2	1	-3	1.5	-5	5
10	10000	-3	2	-4	2	-1e30	5
11	12500	-3	2	-6	3	-1e30	5
12	16000	-3	2	-1e30	3	-1e30	5
13	20000	-3	2	-1e30	3	-1e30	5

2.2.3 Time Weighting Characteristics

The frequency weighted signal is detected and indicated in accordance with one of the time weighted characteristics designated S (slow), F (fast), and I (impulse), which define the dynamic response of the indicator. The F response is similar to the time response of the human ear, while the

2. Measuring of Noise

S response serves for indication of the average amount of sound variation. The I response is provided because the S and F indicators can not correctly measure the intensity of impulsive sound.

The F and S detector-indicator characteristics are obtained by combining the squaring circuit, the exponential averaging circuit with the appropriate time constant, and the indicator calibrated in decibels (Figure 2.6 a). The exponential averaging circuit can be realised by a first order analogue low pass filter (Figure 2.7). The time constant of the circuit specifies how quickly the indication decays when a constant signal is suddenly switched off. The indication decays with the speed of

$$20 \log_{10} e^{-1s/\tau} \frac{dB}{s}, \quad (2.32)$$

where τ is a time constant. For a better idea, this corresponds to the decay of level indication with very short averaging time of a high frequency signal of the form

$$p(t) = p_0 e^{-t/\tau} \cos(\omega t). \quad (2.33)$$

Time constants of the exponential averaging circuit for F and S characteristics are $\tau_F = 125 \text{ ms}$ and $\tau_S = 1000 \text{ ms}$, respectively.

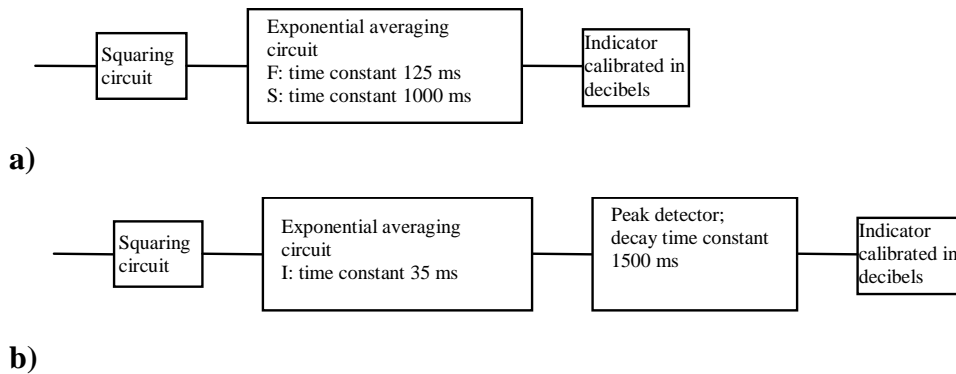

Figure 2.6: Block diagrams for a) F and S and b) for I detector-indicator characteristics.

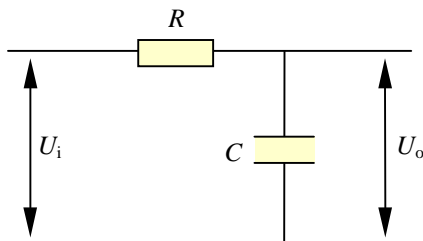

Figure 2.7: Implementation of the exponential averaging circuit by the analogue low pass filter.

The time constant of the exponential averaging circuit for the I time weighting characteristics is $\tau_t = 35ms$. In addition, a peak detector with decay rate 2.9 dB/s (corresponding to the time constant $\tau = 1500ms$) is introduced into the chain (Figure 2.6 b).

2.2.4 Band Pass Filters

In order to analyse the noise spectrum, band pass filters can be attached to a measuring instrument. Octave-band and one-third octave-band filters are usually used in noise measurements. The required properties for band-pass filters used in acoustics are specified by the IEC standard [7]. The standard distinguishes, with respect to permissible lower and upper limits on attenuation, between three classes of filters: type 0, 1 and 2.

An *octave-band filter* transmits the frequencies within an octave range and eliminates the frequencies out of this range. By other words, it eliminates the components of a signal whose frequencies are more than $\frac{1}{2}$ of an octave lower or higher than the filter *midband frequency*. An *octave* is a frequency ratio of $G=2$ between the higher and the lower frequency of a frequency interval. The IEC standard^[7] permits base-two and base-ten options for determining octave- or fractional octave-band frequency ratio¹:

$$\begin{aligned} G_{10} &= 10^{3/10} \approx 1.9953 \\ G_2 &= 2 \end{aligned} \quad (2.34)$$

Octave- and fractional octave-band filters are characterised by the *bandwidth designator* $1/b$. It designates the fraction of an octave band and is a reciprocal of a positive integer (e.g. 1 for octave-band and $1/3$ for one-third octave-band filters). The standard specifies the admissible midband frequencies. When b is an odd number, the midband frequencies of any filter in a set are determined from

$$f_m = G^{x/b} f_r, \quad (2.35)$$

where x is any integer and f_r is the *reference frequency* of 1000 Hz.

The *bandedge frequencies* f_1 and f_2 of a bandpass filter are the lower and upper edges of the passband of the filter such that the midband frequency is the geometric frequency of f_1 and f_2 ($f_m = \sqrt{f_1 f_2}$):

¹ The base-two system is adopted in this document.

$$\begin{aligned} f_1 &= G^{-1/(2b)} f_m \\ f_2 &= G^{1/(2b)} f_m \end{aligned} \quad (2.36)$$

In practice it is not possible to design band-pass filters with zero-one permeability. The standard^[7] therefore prescribes the lower and upper bounds on the relative attenuation of band-pass filters. These limits are listed in Table 2.3 and Figure 2.8. The *relative attenuation* is defined as

$$\Delta A(f/f_m) = A(f/f_m) - A_{ref} \quad (2.37)$$

A_{ref} is a nominal filter attenuation in the passband as specified by the manufacturer for determining the relative attenuation. $A(f/f_m)$ is the filter attenuation at the *normalised frequency* $\Omega = f/f_m$, which is the level of the time-mean-square input signal minus the level of the time-mean-square of the output signal, in decibels.

Table 2.3: Prescribed lower and upper bounds on octave-band filter response (relative attenuation ΔA in decibels) for filters of type 0, 1 and 2. Index i is a measure of frequency, i.e. $f_i = f_m 2^i$, where f_m is the midband frequency of the filter. Limits are symmetric, which means that minimum and maximum responses for negative indices are the same as for their absolute values.

i	0-	0+	1-	1+	2-	2+
0	-0.15	0.15	-0.3	0.3	-0.5	0.5
0.125	-0.2	0.15	-0.4	0.3	-0.6	0.5
0.25	-0.4	0.15	-0.6	0.3	-0.8	0.5
0.375	-1.1	0.15	-1.3	0.3	-1.6	0.5
0.5	-4.5	0.15	-5	0.3	-5.5	0.5
0.5	-4.5	-2.3	-5	-2	-5.5	-1.6
1	$-\infty$	-18.0	$-\infty$	-17.5	$-\infty$	-16.5
2	$-\infty$	-42.5	$-\infty$	-42	$-\infty$	-41
3	$-\infty$	-62	$-\infty$	-61	$-\infty$	-55
4	$-\infty$	-75	$-\infty$	-70	$-\infty$	-60

Figure 2.8: Graphical illustration of bounds on admitted response of type 1 octave-band filters.

The limits on relative attenuation of the fractional-octave band filters can be determined from the limits prescribed for the octave-band filters at the corresponding normalised frequency.

3. The Metrel Sound Level Meter

The high-frequency fractional-octave-band normalised frequency $\Omega_{h(1/b)}$, which corresponds to the relative attenuation limits for the same accuracy class of the octave-band filter at the normalised frequency $\Omega = f/f_m > 1$, is calculated from

$$\Omega_{h(1/b)} = 1 + \frac{G^{1/(2b)} - 1}{G^{1/2} - 1} (\Omega - 1). \quad (2.38)$$

For $\Omega < 1$, its corresponding low-frequency fractional-octave-band normalised frequency is calculated from

$$\Omega_{l(1/b)} = \frac{1}{\Omega_{h(1/b)}}. \quad (2.39)$$

Between the normalised frequencies Ω_a and Ω_b for which the limits on relative attenuation are specified in Table 2.3 for octave-band filters, or between comparable frequencies for fractional-octave-band filters, the upper or lower limit for relative attenuation is be calculated according to the following linear interpolation formula:

$$\Delta A_x = \Delta A_a + (\Delta A_b - \Delta A_a) \left(\frac{\log(\Omega_x/\Omega_a)}{\log(\Omega_b/\Omega_a)} \right), \quad (2.40)$$

where ΔA_a is the prescribed relative attenuation limit at Ω_a , ΔA_b is the prescribed relative attenuation limit at Ω_b and ΔA_x is the searched relative attenuation limit at an intermediate normalised frequency $\Omega_a < \Omega_x < \Omega_b$.

3 THE METREL SOUND LEVEL METER

3.1 *The Structure of the Instrument*

The structure of the Metrel sound level meter is shown schematically in Figure 3.1. The sound pressure field is captured by a condensor microphone, which converts the fluctuating sound pressure to a continuous electrical signal. This signal is preamplified to a level suitable for further processing and digitalised by an ADC. All further processing is then performed on a digital signal¹. An input test signal can be attached before the ADC.

¹ In this way potential problems arising from ageing of analogue components are avoided. Except for the microphone and preamplifier, the characteristics of the instrument is not subjected to change with time.

3. The Metrel Sound Level Meter

The digital signal first passes an amplifier with variable amplification, which serves for calibration. A set of frequency weighting filters follows. The user can switch between A, B and C frequency weighting, or choose the Lin response (no frequency weighting).

The signal then passes a set of octave or one-third octave- band filter. If one of the filtering is switched on, the levels of the signal in octave or one-third octave intervals are shown by the instrument.

The filtered signal is squared and treated by the averaging circuit. Either the S, F or I time weighting characteristics of the averaging circuit can be chosen by the user. After the signal passes the averaging circuit, its dynamics becomes much different from the dynamics of the fluctuating sound pressure. Instead of reflecting the sound pressure variation, the signal level now reflects the r.m.s. (root mean square) of the sound pressure, which is obtained by averaging the square of the signal and applying the square root to the averaged value. When a non-steady sound whose intensity changes with time is measured, the level of the signal follows the variation of the measured sound intensity with a slight delay, dependent on the time constant of the averaging circuit¹.

After averaging, the logarithm is applied to the signal in order to obtain the level in decibels. This level is displayed on the LCD display as the sound pressure level. Beside displaying the instantaneous value of the sound pressure level, the integrating unit can be applied in order to calculate integral and statistical values over longer periods (see the instruction manual).

The instrument consists of the processing / displaying unit and a sound probe with a microphone. The sound probe can be attached directly to the instrument for measurement by hand, where one holds the instrument in his or her hand and directs it towards the source of noise to be measured. Another option is to attach the probe to the processing unit by a cable. The sound should be placed on a stand, so that it can be precisely and positioned and directed. The advantage of such arrangement is that the microphone is fixed and the measurer can withdraw in order not to disturb the measured sound field.

The input signal generated by the microphone can be replaced by an analogue electrical input signal. This can be used for testing of the electronic part of the instrument by observing the response to a known input signal generated by a signal generator.

The instrument has an AC (alternate current) and a DC (direct current) analogue output. The AC output is captured after the frequency weighting circuits upon DA conversion. It corresponds to the frequency weighted amplified signal from the microphone. When the Lin weighting is chosen, the frequency weighting is not applied and the AC output signal is proportional to the output of the microphone. The AC output signal can be used for example for the Fourier analysis of the sound pressure field.

The DC output is captured after the logarithmic unit and therefore corresponds to the frequency weighted and time averaged sound pressure level in decibels. The DC output can be used for recording and later analysis of the noise level.

¹ The current level of the signal after averaging is proportional to a weighted average of the squared sound pressure over some time period, with weights falling exponentially with the time elapsed since the sound pressure was captured and the time constant in the exponent specified by the time weighting characteristics applied – one of the S, F, or I.

3. The Metrel Sound Level Meter

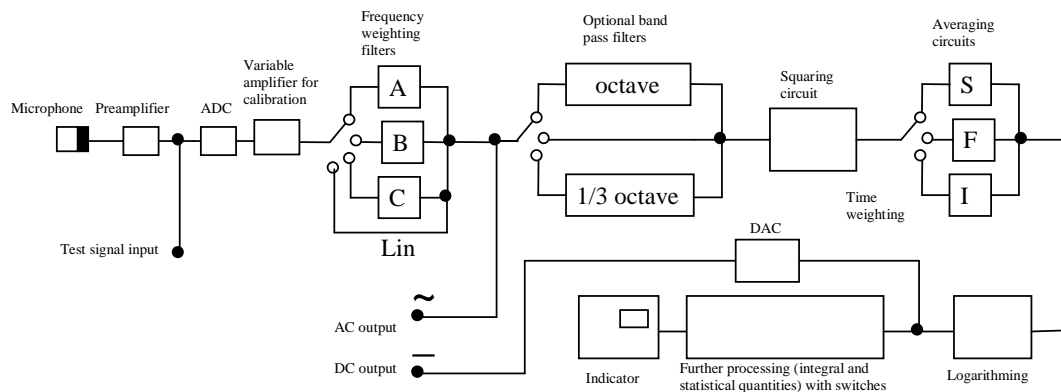

Figure 3.1: Scheme of the Metrel sound level meter.

3.2 Testing and Measuring Accuracy

The instrument can be used either as a type 1 or type 2 instrument (according to [3]), dependent on the microphone used. The microphone is screwed on the end of the sound probe and can be replaced. The instrument is provided either by the type 1 or type 2 microphone. After the microphone is exchanged, the instrument must be re-calibrated even if both microphones have the same nominal sensitivity.

The instrument has undergone the appropriate tests in order to confirm the compliance with the IEC standards [3] to [7]. Testing according to these standards include the following: [3]:

- test of frequency weighting
- test of directional sensitivity
- test of overload detector characteristics
- test of detector and indicator characteristics:
- single burst test
- overshoot with suddenly applied signal
- overshoot with signals with a step in amplitude
- test of decay time by a signal suddenly turned off
- test of r.m.s. performance by comparing the indication for a reference sinusoidal signal by the indication for a sequence of tone bursts and a sequence of rectangular pulses
- test of the I weighting characteristics
- test of onset time for the peak detector

[6]:

- test of time averaging
- linearity range
- test of the pulse range

[7]:

- test of relative attenuation
- filter integrated response
- linearity of response
- test of real-time operation
- test of anti-alias filters
- test of summation of output signals
- sensitivity to environment
- sensitivity to electrostatic discharge

[5]:

- measurement of radio-frequency emission
- test for electrostatic discharge
- test for immunity to power- and radio-frequency fields and conducted disturbances

3.3 Calibration of the Instrument

The whole processing part of the instrument is implemented in digital technology. The microphone and the preamplifier are the only components of the instrument whose characteristics can change with time and is sensitive to environmental conditions such as the temperature or humidity. Frequency or time weighting characteristics are therefore not of concern when calibrating the instrument, and the instrument is calibrated only with respect to the indicated level.

The instrument can be calibrated by any acoustic calibrator that satisfies the accuracy requirements and is suitable for calibration of ½" free field microphones. Some possible options are the Multifunction Acoustic Calibrator – type 4226, the Sound Intensity Calibrator – type 3541, and the Pistonphone – type 4228, all produced by the Bruel & Kjaer.

Calibration should be performed with a sinusoidal sound wave of the reference frequency of 1 kHz. The general calibration procedure is as follows:

1. Set frequency weighting of the instrument to Lin, and time weighting to F.
2. Set the measurement range to the maximum.
3. Insert the microphone of the sound level meter into the hole of the calibrator's acoustic coupler.
4. Turn on the power of the calibrator.
5. Set the calibration value to the appropriate level. The highest available level which is within of the instrument measuring range is recommended.
6. Turn the gain adjustment of the variable amplifier until the indicated level read on instrument display matches the calibration sound level of the acoustic calibrator. Make sure that calibrator indicates that the constant level is obtained.

Refer also to the instructions of the calibrator on how to perform the calibration. Consult also the microphone datasheet for the difference between the pressure and free field response. Note that the response of the microphone placed in an acoustic calibrator is the pressure response.

3.4 Maintenance and Care

The instrument may not be exposed to extremely high or low temperatures, high air humidity, water or chemically aggressive substances such as acids. Protect the instrument from mechanical damage: take care not to hit any objects by the instrument and not to drop it. Store the instrument appropriately when it is not in use. Note that especially the sound probe is sensitive to mechanical and damage. it is advisable to detach the probe after measurement.

References:

- [1] F. W. Sears, M. W. Zemansky, H. D. Young, *University Physics*, Reading, Mass. (Addison Wessley), 1960.
- [2] E. Kreyszig: *Advanced Engineering Mathematics*, 7th edition, John Wiley & Sohns, 1993.
- [3] Standard IEC 651: *Sound Level Meters*, 1979
- [4] Standard IEC 651, *Amendment 1 to Sound Level Meters*, 1993 (Corrections to IEC 651 –remark).
- [5] Standard IEC 60651, *Amendment 2 to Sound Level Meters*, 2000 (electromagnetic and electrostatic compatibility requirements –remark).
- [6] Standard IEC 804, *Integrating–averaging Sound Level meters*, 1985.
- [7] Standard IEC 1260, *Electroacoustics – Octave-band and Fractional Octave-band Filters*, 1995.

3. The Metrel Sound Level Meter

V poglavju 1.1.3 slike o različnih pojavih

Dodati: v poglavju 1.1.3.1 D'Alembertove rešitve (morda omeniti Huyghensov princip)

Referenca na instruction manual!!!! (definicije tipk, kako vklopiti zacetek integracije, nastavitve integracijske periode itd.)

Preveriti pri opisu kalibracije, ce ustreza dejanski izvedbi (tj. ali obstaja vrtljiv gumb za nastavitve kalibrac. ojačevalnika ali se ojačanje nastavi in shrani kako drugace)

Navesti, kateri mikrofoni pridejo z instrumentom za tip 1 in tip 2!